

# BELLY DUMP BOX DETAIL SHEET

Please complete form thoroughly. Missing information may delay order processing.

TruckTarpStore.com  
PO Box 1148  
Jamestown, ND 58402

Phone: (888) 814-4327  
Fax: (701) 252-4529  
info@trucktarpstore.com

**NOTE: Accurate PHYSICAL measurements are ESSENTIAL for proper tarp fit. Always use actual tape measurements. NEVER RELY ON UNIVERSAL BOX SIZES.**

Sales Representative: \_\_\_\_\_

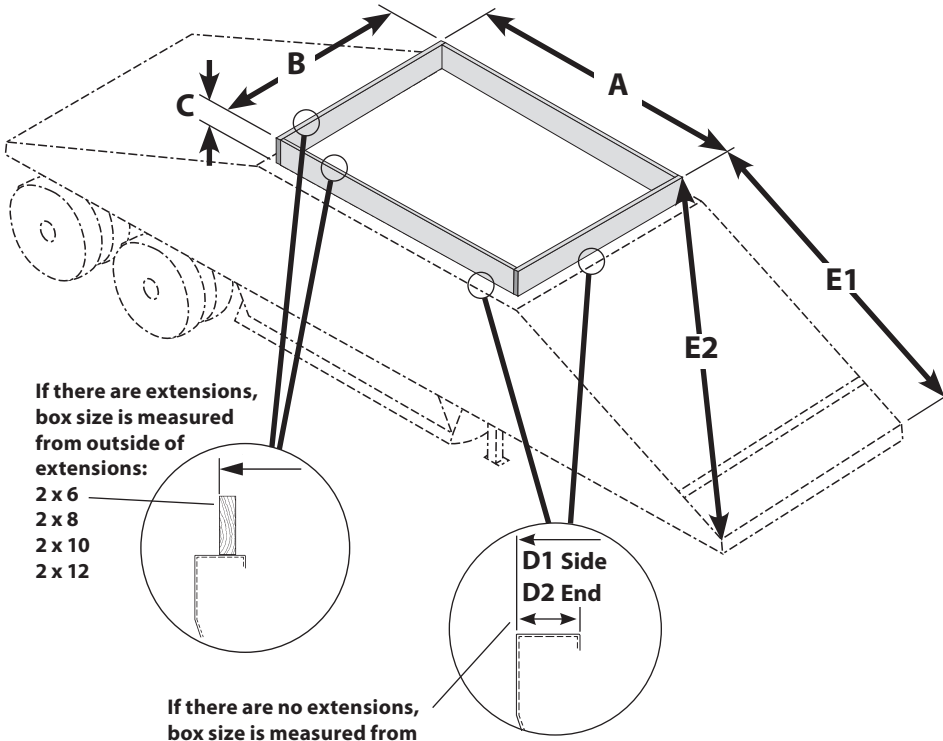

If there are extensions, box size is measured from outside of extensions:

- 2 x 6
- 2 x 8
- 2 x 10
- 2 x 12

If there are no extensions, box size is measured from outside of steel sides.

**IMPORTANT:** Illustration shows taking measurements at top of extensions (tip-tops) - If no extensions, take measurements at top of box.

**SPECIAL NOTES:**

\_\_\_\_\_

\_\_\_\_\_

\_\_\_\_\_

\_\_\_\_\_

\_\_\_\_\_

\_\_\_\_\_

\_\_\_\_\_

\_\_\_\_\_

\_\_\_\_\_

\_\_\_\_\_

**CONTACT INFORMATION**

Name \_\_\_\_\_

Address \_\_\_\_\_

City \_\_\_\_\_ State \_\_\_\_\_ Zip \_\_\_\_\_

Phone \_\_\_\_\_ Fax \_\_\_\_\_

Trailer Brand /Year \_\_\_\_\_

**TYPE OF TARP SYSTEM**

SRT-2™ Manual     SRT-2™ Electric\*     SRT-2™ Wireless Remote Option\*

**TARP COLOR**

Standard:

Black     White

Optional\*:

Gray     Blue     Red     Orange

Green     Brown     Yellow     Multi-Color

**MESH FABRIC\*** (Available in Black Only)

Yes     No

**OUTSIDE DIMENSIONS**

A \_\_\_\_\_ Top Outside of Extensions/Box Length

B \_\_\_\_\_ Top Outside of Extensions/Box Width

C \_\_\_\_\_ Height of Extensions (when applicable)

D1 \_\_\_\_\_ Top Rail Width Sides

D2 \_\_\_\_\_ Top Rail Width Ends

E **Reference Dimensions for Handle Length**

E1 \_\_\_\_\_ (straight line)    E2 \_\_\_\_\_ (diagonal)

\* Optional items are additional cost