

FERTILIZER SPREADER / TENDER BOX DETAIL SHEET

Please complete form thoroughly. Missing information may delay order processing.

TruckTarpStore.com
PO Box 1148
Jamestown, ND 58402

Phone: (888) 814-4327
Fax: (701) 252-4529
info@trucktarpstore.com

NOTE: Accurate PHYSICAL measurements are ESSENTIAL for proper tarp fit. Always use actual tape measurements. NEVER RELY ON UNIVERSAL BOX SIZES.

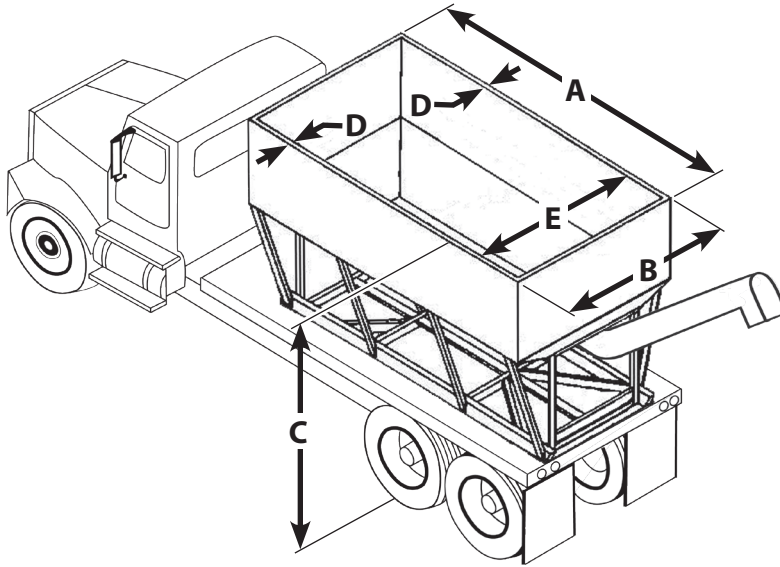

IMPORTANT:

- Manual crank system will not work on air systems with rear manifold distributor.
- Manual cranks will work on most spinner spreaders.
- AirMax/Loral may need an extension, so tarp will roll over far enough to seal, boom rests may need minor modification to clear.
- Ag Chem Spreaders with inside Granular bins require a special rear cap, set back 6".
- Loral units with rear granular attachment utilize same front and rear cap.

SPECIAL NOTES:

Sales Representative: _____

CONTACT INFORMATION

Name _____
Address _____
City _____ State _____ Zip _____
Phone _____ Fax _____

TYPE OF TARP SYSTEM

- | | |
|---|--|
| <input type="checkbox"/> SRT-2™ Manual | <input type="checkbox"/> EZ-LOC® Manual |
| <input type="checkbox"/> SRT-2™ Electric* | <input type="checkbox"/> EZ-LOC® Electric* |
| <input type="checkbox"/> SRT-2™ Wireless Remote Option* | <input type="checkbox"/> EZ-LOC® Wireless Remote Option* |

TARP COLOR

Standard:

- Black White

Optional*:

- | | | | |
|--------------------------------|--------------------------------|---------------------------------|--------------------------------------|
| <input type="checkbox"/> Gray | <input type="checkbox"/> Blue | <input type="checkbox"/> Red | <input type="checkbox"/> Orange |
| <input type="checkbox"/> Green | <input type="checkbox"/> Brown | <input type="checkbox"/> Yellow | <input type="checkbox"/> Multi-Color |

STYLE OF END CAPS

- Stainless Steel Standard 7"
 Stainless Steel Tall 12" (recommended)

SPREADER

Make: _____
Model: _____ Year: _____
Granular Bin: Inside Box Outside Box
Spreader Style:
 Self Propelled Air System
 Spinner Pull Type Spinner

TENDER

Make: _____
Model: _____ Year: _____
 Truck Mounted Tender Mounted
Spreader Style:
 Rear Side Fold Rear Rear Over Box

OUTSIDE DIMENSIONS

A _____ Top Outside Box Length
B _____ Top Outside Box Width
(If box has Extensions measure outside of extensions on the angle)
C _____ Box Height (from ground)
D _____ Top Rail Width
E _____ Inside Box Width

* Optional items are additional cost