

GRAIN CART / WAGON BOX DETAIL SHEET

Please complete form thoroughly. Missing information may delay order processing.

TruckTarpStore.com
PO Box 1148
Jamestown, ND 58402

Phone: (888) 814-4327
Fax: (701) 252-4529
info@trucktarpstore.com

NOTE: Accurate PHYSICAL measurements are ESSENTIAL for proper tarp fit. Always use actual tape measurements. NEVER RELY ON UNIVERSAL BOX SIZES.

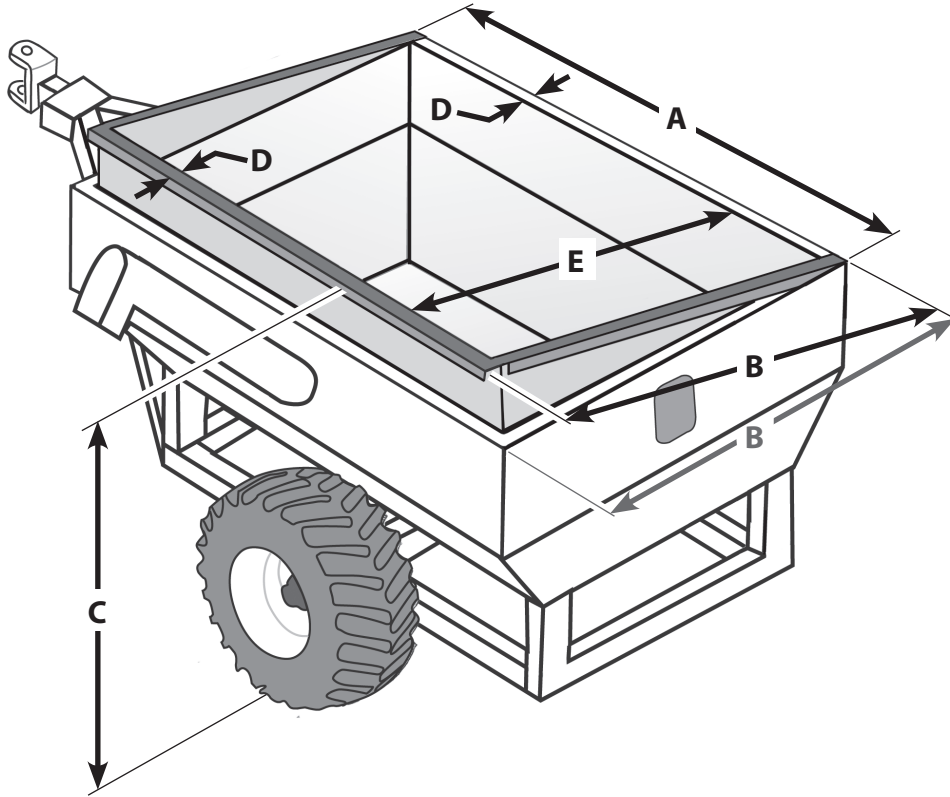

IMPORTANT: Illustration shows measuring at top of angled extensions - or - If no extensions, measuring at top of box.

NOTE: If ordering flat or top mount end caps, make sure box is flat across top. Below is an example of a box with uneven angle across top from high side to low side. Flat or top mount caps will not fit this box. Order side mount caps for these boxes.

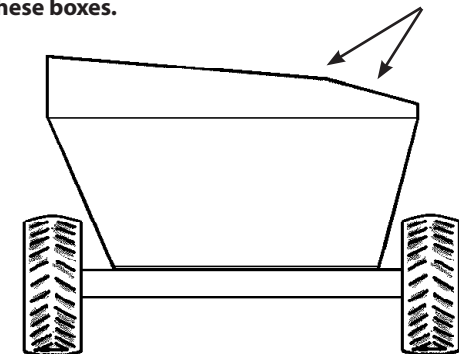

Sales Representative: _____

CONTACT INFORMATION

Name _____

Address _____

City _____ State _____ Zip _____

Phone _____ Fax _____

Cart/Wagon Brand/Year _____

TYPE OF TARP SYSTEM

- | | |
|---|--|
| <input type="checkbox"/> SRT-2™ Manual | <input type="checkbox"/> EZ-LOC® Manual |
| <input type="checkbox"/> SRT-2™ Electric* | <input type="checkbox"/> EZ-LOC® Electric* |
| <input type="checkbox"/> SRT-2™ Wireless Remote Option* | <input type="checkbox"/> EZ-LOC® Wireless Remote Option* |

TARP COLOR

Standard:

- Black White

Optional*:

- Gray Blue Red Orange
 Green Brown Yellow Multi-Color

STYLE OF END CAPS

- Galvanized Standard 12"
 Aluminum* Standard 12" (up to 118" wide only)
 Stainless Steel* Standard 12" (up to 118" wide only)
 Galvanized Flat* (138"-144" wide only)

OUTSIDE DIMENSIONS

- A _____ Top Outside Box Length
B _____ Top Outside Box Width
(If box has Extensions measure outside of extensions on the angle)
C _____ Box Height (from ground)
D _____ Top Rail Width
E _____ Inside Box Width

* Optional items are additional cost